



Wireless Gateway GW900-3G/4G User Manual (EN)

<PC24_BDC_AG02_001> Version 1.51

Date: 2025-11-17

Manufacturer

I-care SRL
Rue René Descartes 18
7000 Mons
Belgium

Copyright

The documentation and the software included with this product are copyrighted by I-care. All rights are reserved. I-care reserves the right to make improvements in the products described in this manual and descriptions in this manual at any time without notice. No part of this manual may be reproduced, copied, translated or transmitted in any form or by any means without the prior written permission of I-care. Information provided in this manual is intended to be accurate and reliable. However, I-care assumes no responsibility for its use, nor for any infringements of the rights of third parties, which may result from its use.

Acknowledgements





Wi-care is a registered trademark of I-care.
All other product names or trademarks are properties of their respective owners.

Important Notice

For your safety, it is imperative that you read and abide by all the instructions given in this user manual.

Note: This equipment has been tested and found to comply with the limits for a Class A digital device, pursuant to part 15 of the FCC Rules. These limits are designed to provide reasonable protection against harmful interference when the equipment is operated in a commercial environment. This equipment generates, uses, and can radiate radio frequency energy and, if not installed and used in accordance with the instruction manual, may cause harmful interference to radio communications. Operation of this equipment in a residential area is likely to cause harmful interference in which case the user will be required to correct the interference at his own expense.

This User Manual includes safety information. The following icons are used:

	Indicates a potentially hazardous situation which, if not avoided, will result in death or serious injury.
	Indicates a potentially hazardous situation which, if not avoided, could result in death or serious injury.
	Indicates a hazardous situation, which if not avoided, could result in minor or moderate injury.
	Addresses practices not related to personal injury.

The photographs, diagrams and illustrations in this manual are provided as indications to clarify the information given. I-care denies any liability in relation to the validity of the images contained in this document.

Table of contents

Important Notice	3
A. Introduction	6
a. Wi-care System.....	7
b. This device “Wireless Gateway GW900-3G/4G”	9
i. Marking Labels.....	11
ii. Symbols as part of the markings.....	13
B. Safety information	15
a. X-Conditions / Specific Conditions of Use for Wireless Gateway GW900-4G-xx Ex.....	15
b. Specific Conditions of Use for Class II (Combustible Dust) Locations (GW900-4G-US Ex only).....	16
c. All devices.....	17
C. Installation	18
a. Location.....	19
b. Mounting procedure.....	19
c. Wiring instructions.....	22
i. Wiring steps (Non-Ex devices only).....	27
D. Maintaining devices	29
a. Explosive Atmospheres (all Ex devices).....	29
b. Class II (Combustible Dust) Locations (US Ex devices only).....	29
i. Regular Inspection and Cleaning Schedule.....	30
ii. Cleaning Procedure.....	30
iii. Inspection Checklist.....	30
c. All devices.....	31
E. Repairs	33
F. Taking Out of Service and Dismantling	34
G. Specifications and environmental constraints	35
H. Compliance	39
a. Ex Certifications.....	39
i. Assessment standards of the Ex certifications.....	39
b. Radio Compliance for WG150160y-02.....	40
c. Radio Compliance for WG150161y-02.....	40
i. Federal Communications Commission (FCC).....	40
Supplier's Declaration of Conformity – 47 CFR § 2.1077 Compliance Information.....	40
ii. Innovation, Science and Economic Development Canada (ISED) Compliance (RSS GEN Issue 5)..	41

- d. Radio Compliance for WG150164y-02..... 41
- I. Manufacturer and Authorized Distributors..... 42**
 - a. Manufacturer.....42
 - b. Legal Representatives.....42
 - i. USA.....42
 - ii. Brazil.....42
 - c. Authorized support via email.....43
 - d. Authorized Distributors..... 43
- J. Additional information..... 44**
 - a. Warranty.....44
 - b. Frequent problems and solutions provided..... 44
 - c. Practical information..... 44

A. Introduction

This document is intended for user information of the device Wireless Gateway GW900-3G/4G with derived models for the European Economic Area (EEA) and North America (USA/Canada) including special models intended for the use in explosive hazardous environments¹ (Ex) with model numbers WG15016xy-02 (where y is a digit used only for Ex devices → detailed overview in the table below). This document contains instructions and safety information including installation instructions.

Read this manual carefully before using the device. Keep it for further reference.

This document is relevant for the following products with the following model numbers only:

Commercial Product Names:	Wireless Gateway GW900-3G- EU
	Wireless Gateway GW900-4G- EU
	Wireless Gateway GW900-4G- GL
	Wireless Gateway GW900-4G- US
	Wireless Gateway GW900-4G- EU Ex
	Wireless Gateway GW900-4G- GL Ex
	Wireless Gateway GW900-4G- US Ex
Model numbers	WG15016 0 -02
	WG15016 0H -02
	WG15016 0L -02
	WG15016 1 -02
	WG15016 1H -02
	WG15016 1L -02
	WG15016 3 -02
	WG15016 4 -02
	WG15016 4H -02
	WG15016 4L -02

While non-Ex models offer both AC and DC input, Ex models (identified by an additional letter in the model number) are available in either AC or DC only. Here is the overview of the commercial names, the model numbers and the key features:

¹ Further common terms are Explosive Atmospheres or Hazardous Areas.

Ex compliance	Non-Ex	IECEX/ATEX/HazLoc (type of protection: Increased Safety and Encapsulation Ex eb mb)	
Input voltage Cellular radio module	100 - 240 VAC / 24 VDC	100 - 240 V AC only	24 V DC only
for Europe 4G	Wireless Gateway GW900-4G- EU WG150160-02	Wireless Gateway GW900-4G- EU Ex WG150160 H -02	Wireless Gateway GW900-4G- EU Ex WG150160 L -02
for Europe 3G	Wireless Gateway GW900- 3G-EU WG150163-02	-	-
for North America	Wireless Gateway GW900-4G- US WG150161-02	Wireless Gateway GW900-4G- US Ex WG150161 H -02	Wireless Gateway GW900-4G- US Ex WG150161 L -02
Global	Wireless Gateway GW900-4G- GL WG150164-02	Wireless Gateway GW900-4G- GL Ex WG150164 H -02	Wireless Gateway GW900-4G- GL Ex WG150164 L -02

This device will work as a product within a system called the *Wi-care system*. The following section describes the system first, before the device itself.

a. Wi-care System

To understand the functionality of the device, here is an overview of the system in which the device will be embedded:

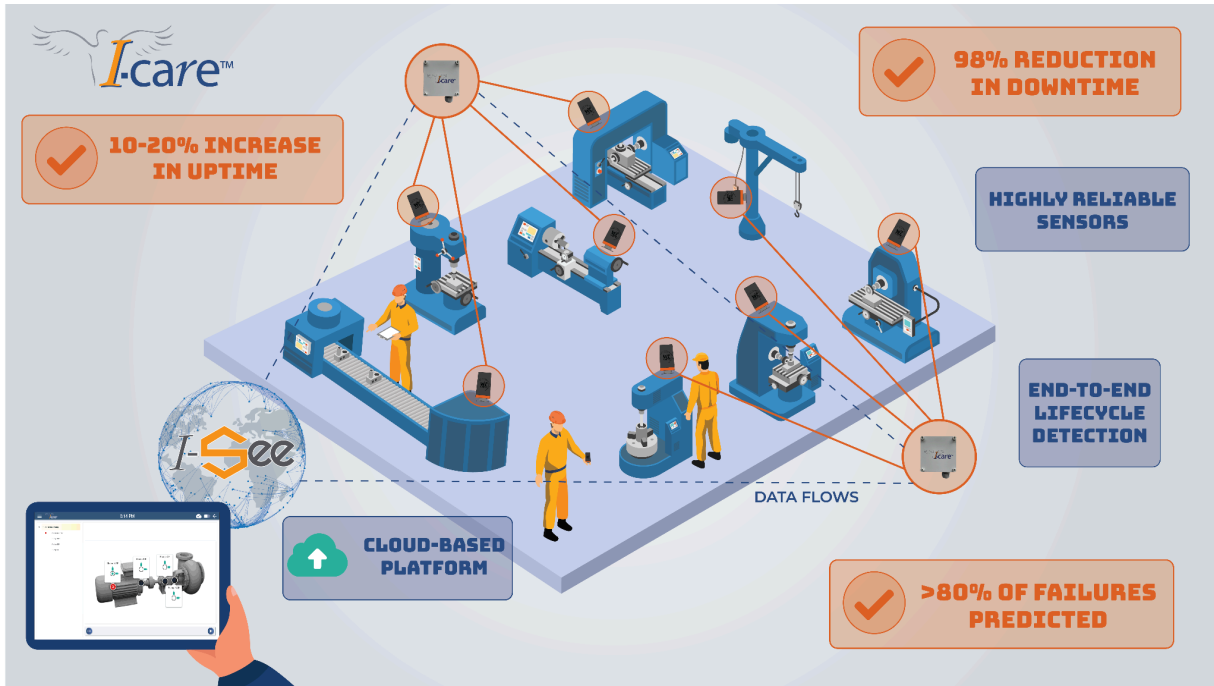

- The *Wi-care* system is a wireless system capable of acquiring temporal and spectral vibration and temperature data on industrial equipment.
- The system provides an alternative to manual wired data collection and enables the use of cables to be avoided.
- The *Wi-care* system allows periodic monitoring and off-site diagnosis.

The system is composed of 2 separate elements:

Element	Role
Transmitter	Collecting and transmitting information on the condition of the equipment to the gateway.
Gateway	Managing Transmitters, sending data to I-see.

b. This device “Wireless Gateway GW900-3G/4G”

This document focuses only on the device “Wireless Gateway GW900-3G/4G” of the Wi-care system:



- This device is the device to receive OpenThread wireless data from the Transmitters which are separate devices within a *Wi-care system*.
- This device uses cellular network to forward received data to I-care’s cloud (I-see™).
- This device manages the OpenThread network and sends tasks each 15 min to typically around 10 Transmitters. Connection is designed to be stable up to an amount of maximum 50 Transmitters connected to a Gateway.

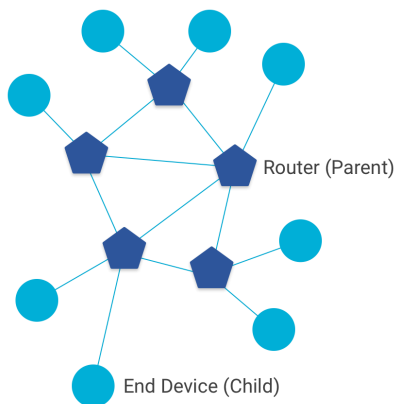

- Gateways can build a mesh network to increase the range or network quality.
- This device is powered by 100-240 VAC 50/60 Hz or 24 VDC.

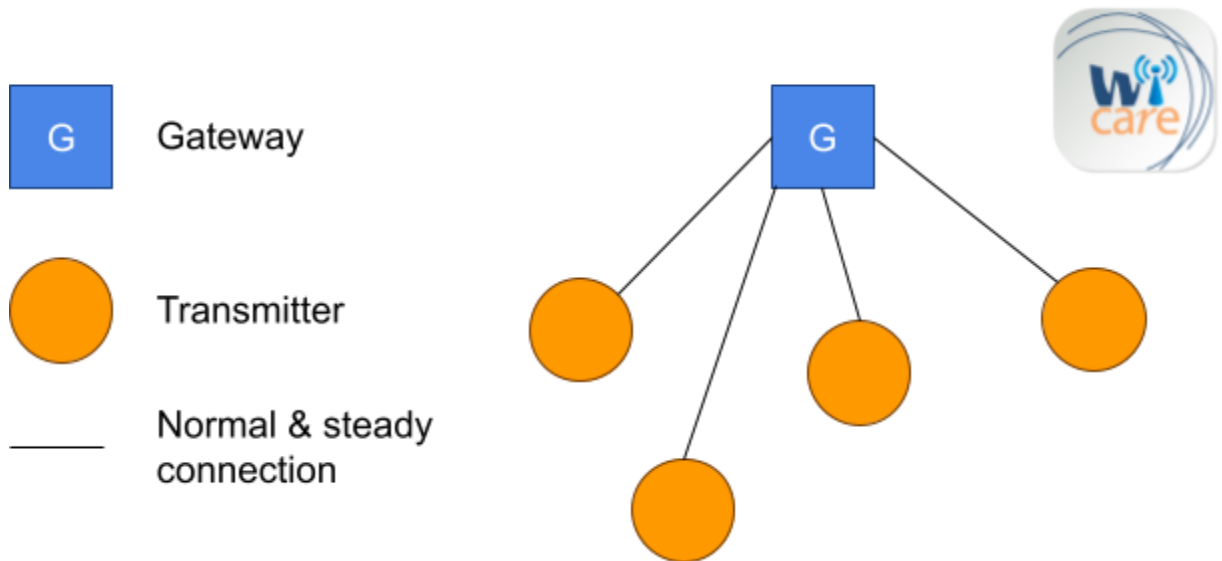

Implementing a *Wi-care system* provides flexible remote diagnostics, available periodically or on demand, making it a versatile tool for industrial maintenance needs. This system integrates easily into a variety of maintenance strategies, including:

- Condition-based Maintenance
- Predictive Maintenance
- Proactive Maintenance
- Prescriptive Maintenance

For guidance on implementing and optimizing these maintenance strategies with your *Wi-care system*, please don't hesitate to contact your local distributor.

i. Marking Labels











Not all model numbers are shown below. But the following markings are representative for the product family.





Ex compliance	Non-Ex	ATEX/IECEX/HazLoc	
Input voltage Cellular radio module	100 - 240 VAC / 24 VDC	100 - 240 VAC only	24 VDC only
for Europe 4G	<p>Wireless Gateway GW900-4G-EU Made in Belgium</p> <p>I-care SRL, Rue René Descartes 18, 7000 Mons, Belgium</p> <p>Mod#: WG150160-02 S/N: WGBExxxxxxx</p> <p>CE</p> <p>100-240 VAC 50/60 Hz; P_m = 1,8 W 24 VDC; P_m = 1,8 W</p> <p>IP66</p> <p>Read Manual Electrical Shock Hazard Do not open While powered</p> <p>Leia o Manual Perigo de Choque Elétrico Não abra enquanto estiver ligado</p>	<p>Wireless Gateway GW900-4G-EU Ex Made in Belgium</p> <p>I-care SRL, Rue René Descartes 18, 7000 Mons, Belgium</p> <p>Mod#: WG150160H-02 S/N: WGBExxxxxxx</p> <p>CSANe 25ATEX1082X IECEX CSA 25.0040X</p> <p>II 2 G CE 0035 Ex eb mb IIC T4 Gb (-15 °C ≤ Ta ≤ +60 °C)</p> <p>IP64</p> <p>WARNING – READ MANUAL – POTENTIAL ELECTROSTATIC CHARGING HAZARD Electrical Shock Hazard</p> <p>AVISO – LEIA O MANUAL – POTENCIAL PERIGO DE CARGA ELETROSTÁTICA Perigo de Choque Elétrico</p>	<p>Wireless Gateway GW900-4G-EU Ex Made in Belgium</p> <p>I-care SRL, Rue René Descartes 18, 7000 Mons, Belgium</p> <p>Mod#: WG150160L-02 S/N: WGBExxxxxxx</p> <p>CSANe 25ATEX1082X IECEX CSA 25.0040X</p> <p>II 2 G CE 0035 Ex eb mb IIC T4 Gb (-15 °C ≤ Ta ≤ +60 °C)</p> <p>24 VDC; P_m = 1,8 W</p> <p>IP64</p> <p>WARNING – READ MANUAL – POTENTIAL ELECTROSTATIC CHARGING HAZARD Electrical Shock Hazard</p> <p>AVISO – LEIA O MANUAL – POTENCIAL PERIGO DE CARGA ELETROSTÁTICA Perigo de Choque Elétrico</p>

Ex compliance	Non-Ex	ATEX/IECEX/HazLoc	
Input voltage	100 - 240 VAC / 24 VDC	100 - 240 VAC only	24 VDC only
Cellular radio module			
for North America	<p>Wireless Gateway GW900-4G-US Made in Belgium</p> <p>I-care SRL, Rue René Descartes 18, 7000 Mons, Belgium</p> <p>Mod#: WG150161-02 S/N: WGBExxxxxx</p> <p>This device complies with Part 15 of the FCC Rules. Operation is subject to the following two conditions: (1) This device may not cause interference. (2) This device must accept any interference, including interference that may cause undesired operation. FCC ID: 2AIV8AG02-02 IC: 33597-AG0202 HWIN: WG150161R13 Contains FCC ID: XMR202008EG91NAXD Contains IC: 10224A-21EG91NAXDL</p> <p>100-240 VAC 50/60 Hz; P_n = 1.8 W 24 VDC; P_n = 1.8 W</p> <p>Read Manual Lire le manuel Electrical Shock Hazard Risque de choc électrique Do not open While powered Ne pas ouvrir sous tension</p>	<p>Wireless Gateway GW900-4G-US Ex Made in Belgium</p> <p>I-care SRL, Rue René Descartes 18, 7000 Mons, Belgium</p> <p>Mod#: WG150161H-02 S/N: WGBExxxxxx</p> <p>This device complies with Part 15 of the FCC Rules. Operation is subject to the following two conditions: (1) This device may not cause interference. (2) This device must accept any interference, including interference that may cause undesired operation. FCC ID: 2AIV8AG02-02 IC: 33597-AG0202 HWIN: WG150161R13Ex Contains FCC ID: XMR202008EG91NAXD Contains IC: 10224A-21EG91NAXDL</p> <p>100-240 VAC 50/60 Hz; P_n = 1.8 W</p> <p>WARNING – READ MANUAL – POTENTIAL ELECTROSTATIC CHARGING HAZARD AVERTISSEMENT – LIRE LE MANUEL – RISQUE POTENTIEL DE CHARGE ÉLECTROSTATIQUE Electrical Shock Hazard Risque de choc électrique</p>	<p>Wireless Gateway GW900-4G-US Ex Made in Belgium</p> <p>I-care SRL, Rue René Descartes 18, 7000 Mons, Belgium</p> <p>Mod#: WG150161L-02 S/N: WGBExxxxxx</p> <p>This device complies with Part 15 of the FCC Rules. Operation is subject to the following two conditions: (1) This device may not cause interference. (2) This device must accept any interference, including interference that may cause undesired operation. FCC ID: 2AIV8AG02-02 IC: 33597-AG0202 HWIN: WG150161R13Ex Contains FCC ID: XMR202008EG91NAXD Contains IC: 10224A-21EG91NAXDL</p> <p>24 VDC; P_n = 1.8 W</p> <p>WARNING – READ MANUAL – POTENTIAL ELECTROSTATIC CHARGING HAZARD AVERTISSEMENT – LIRE LE MANUEL – RISQUE POTENTIEL DE CHARGE ÉLECTROSTATIQUE Electrical Shock Hazard Risque de choc électrique</p>

ii. Symbols as part of the markings

The following symbols are at least part of the marking of some models:

	Refer to the user manual (this document). A QR code links to the document online. Further documents and videos related to this device are accessible there.
	Caution! Please note the additional instructions associated with this symbol.
	The user manual (this document) contains important safety information. Please refer to this document when operating the device.
	Caution, risk of electric shock! Please note the additional instructions associated with this symbol.
	A Class I protection, meaning the device must be connected to earth (ground) for safety. This prevents electric shock by safely directing fault currents to the ground.
	A Class II or double insulated electrical appliance uses reinforced protective insulation in addition to basic insulation. Hence, it has been designed in such a way that it does not require a safety connection to the ground (electrical earth).
	This symbol means the device follows the EU's WEEE Directive 2012/19/EU. Do not discard this product with normal household waste.
	This symbol shows that the device meets the safety, health, and environmental rules of the European Economic Area (EEA).
	This symbol means the device is approved for use in explosive atmospheres. It meets the safety rules of the EU's ATEX Directive.
	This symbol shows the device meets the standards of the Canadian Standards Association.

 C US	This symbol shows the device meets CSA standards for use in the USA and Canada.
	This symbol certifies that the device's radio functions meet the rules of Japan's Radio Law and Telecommunications Business Law, TBL.
 Segurança NCC INMETRO	This conformity seal certifies that the device is approved by the certification body NCC for use in explosive atmospheres in Brazil.
	This symbol certifies that the device's radio functions meet the rules of Brazil.

B. Safety information

If you use this equipment in a way not specified by the manufacturer, its safety protections can fail. This can cause injuries, damage or equipment malfunction. Always follow the instructions in this manual.

a. X-Conditions / Specific Conditions of Use for Wireless Gateway GW900-4G-xx Ex

This section applies to devices intended for use in potentially explosive atmospheres with the following model numbers only:

Wireless Gateway GW900-4G- EU Ex WG15016 0H -02	Wireless Gateway GW900-4G- EU Ex WG15016 0L -02
Wireless Gateway GW900-4G- US Ex WG15016 1H -02	Wireless Gateway GW900-4G- US Ex WG15016 1L -02
Wireless Gateway GW900-4G- GL Ex WG15016 4H -02	Wireless Gateway GW900-4G- GL Ex WG15016 4L -02

	Indicates a potentially hazardous situation which, if not avoided, will result in death or serious injury.
---	--

To use this device safely and avoid the risk of ignition in explosive or hazardous areas (Ex), always follow these specific conditions:

- Under certain extreme circumstances, the non-metallic parts incorporated in the enclosure of this equipment may generate an ignition-capable level of **electrostatic charge**. Therefore, the equipment shall not be installed in a location where the external conditions are conducive to the build-up of electrostatic charge on such surfaces. In addition, the equipment shall only be cleaned with a damp cloth.
- This equipment shall be installed where the **risk of damage to the equipment due to impact** is considered to be low.
- The **prospective short circuit current** shall be less than 1500 A for AC supply and 100 A for DC supply.

b. Specific Conditions of Use for Class II (Combustible Dust) Locations (GW900-4G-US Ex only)

 WARNING	<p>Ignition Hazard from Hot Surfaces The maximum surface temperature of this device in Class II locations is 135 °C. The user must make sure that the ignition temperature of the combustible dust at the location is safely above this value. Refer to applicable national and local regulations (e.g., NEC Art. 500, NFPA 499) and include a sufficient safety margin.</p>
	<p>Ignition Hazard from Dust Layers Layers of combustible dust on the enclosure act as thermal insulation. This can cause the surface temperature to increase above the rated 135 °C and create an ignition source. You must keep the device free from significant dust layers. Follow the cleaning procedures in the "Maintaining devices" chapter.</p>
	<p>Electrostatic Hazard To prevent an electrostatic discharge that could ignite a dust cloud, clean the enclosure only with a damp or anti-static cloth. Do not use a dry cloth or brush.</p>
	<p>Risk of Explosion The explosion protection of this device is guaranteed only if the enclosure remains sealed. Do not open the enclosure for any reason. All service that requires opening the enclosure must be performed by the manufacturer or by personnel authorized by the manufacturer. Unauthorized opening of the enclosure voids the Ex certification and can lead to death or serious injury.</p>

c. All devices

This section applies to all devices relevant to this document (→ [Introduction](#)).



Indicates a potentially hazardous situation which, if not avoided, could result in death or serious injury.

To use this device safely and prevent electrical shock or fire:

- **Install as Fixed Wiring:** The device must be installed with fixed wiring and an appropriate disconnect device. Do not use power cords or flexible cables. Have a qualified electrician perform all wiring according to all local regulations. Connect only AC or DC input, never both. For non Ex devices: Use only cables that are compatible with the device. (→ [Wiring instructions](#))
- **No Modifications:** Do not modify the device. Changes can damage the double insulation and cause electrical shocks.
- **Check Wiring:** Regularly inspect the fixed wiring for wear or damage. If you find issues, turn off the power with the disconnect device and have a qualified electrician fix or replace the wiring.
- **Inspect Insulation:** Regularly check the device's insulation for cracks or tears. If damaged, turn off the power with the disconnect device and contact the manufacturer or authorized distributor immediately. (→ [Manufacturer and Authorized Distributors](#))
- **Do Not Install Damaged Devices:** Never install a device that is damaged.
- **Ensure Ventilation:** Install the device in a well-ventilated area with clearances of 10 cm to prevent overheating. Poor airflow can cause malfunction or fire hazards.



Indicates a hazardous situation, which if not avoided, could result in minor or moderate injury.

To use the device safely and minimize risks:

- **Avoid Prolonged Exposure:** Do not stay within 20 cm of the device for more than 15 seconds to avoid exposure risks.

**NOTICE**

Addresses practices not related to personal injury.

- The presence of a Wi-care network operating nearby may interfere with the nominal operation of another *Wi-care* system. However the Wi-care network is designed and compliant for use with other wireless networks or radio devices.

C. Installation

The responsibility for ensuring the safety of any system that incorporates this device lies with the system installer.

 WARNING	WARNING FOR CLASS II (Wireless Gateway GW900-4G-US Ex only):
	Risk of Explosion The explosion protection of this device is guaranteed only if the enclosure remains sealed. Do not open the enclosure for any reason. All service that requires opening the enclosure must be performed by the manufacturer or by personnel authorized by the manufacturer. Unauthorized opening of the enclosure voids the Ex certification and can lead to death or serious injury.

To ensure correct installation, follow these main steps:

1. **Select a Suitable Location:** Choose a location that meets the environmental and safety requirements. (→ [Location](#))
2. **Mount the Enclosure:** Securely install the enclosure at the selected location. (→ [Mounting procedure](#))
3. **Perform Fixed Wiring Installation:** Connect the device using fixed wiring according to the provided instructions. (→ [Wiring instructions](#))
4. **Settings and parameterisation:** With the app *I-install* the serial number and the MAC address of the device get integrated into *I-see* which manages the [Wi-care System](#). Contact the [manufacturer or an authorized distributor](#) for support.

For detailed installation procedures, refer to the following sections.

a. Location

	<p>Hazards from fire</p> <ul style="list-style-type: none">● Please select a location that is not affected by mechanical shocks.● Ensure that the device is installed in a location with sufficient airflow to prevent overheating. A distance of 10 cm around the device is sufficient.● Avoid placing the device near or above of heat sources such as radiators or heaters or other equipments operated at higher temperatures than the rated temperature of Wireless Gateway GW900-3G/4G.
---	--

	<p>It is recommended to place the device in an open area, in the vertical direction and high enough (> 1,5 m [5 ft]). This is not mandatory, but it helps to get a longer range of the radio signals.</p> <p>Ensure accessibility to the installed device for maintenance and troubleshooting.</p>
---	---

b. Mounting procedure

The device is intended for wall mounting only. The fitting parts are available outside the enclosure and do not require opening it.

	<p>Fire hazard</p> <ul style="list-style-type: none">● Mount the enclosure with the cable gland facing downwards.● Do not install a damaged device. <p>Mechanical hazards</p> <p>The device shall be installed in a location that minimizes the risk of mechanical impact. For example, install the device at a height or in a position</p>
---	--

where moving objects cannot reach it.²



Mechanical hazards

1. Attach the mounting feet to the enclosure using the supplied screws. Tighten the screws to a torque of 100 to 110 cN-m or 8.8 to 9.7 lbf-in.
2. Mount the enclosure to the desired object:
The power cable must be located on the bottom of the installed enclosure only.
We recommend the use of 4x45mm dowel screws in combination with dowels suitable for the wall material of your installation location.³
4 screws are needed to ensure the correct mounting of the device.

² This installation method is normal: The device operates autonomously and does not require user handling. Radio connections work best when no obstacles block the signal. Elevated positions usually provide the best performance.

³ For example *ASSY-D steel zinc plated countersunk head AW SCR-CS-WO-AW20-(A2K)-4X45/39* combined with *Fischer SX 6 x 30 nylon anchors* is applicable for concrete, brick with vertical perforations, hollow lightweight concrete block, brick and concrete slabs, perforated sand-lime brick, natural stone with dense structure, cellular concrete, plaster tiles, solid block in lightweight concrete, solid brick



Mechanical hazards

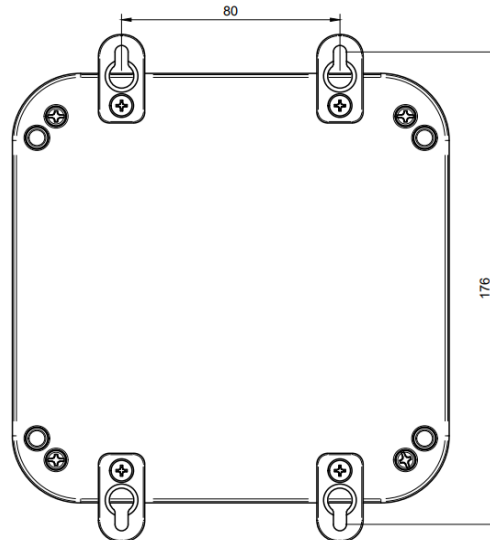
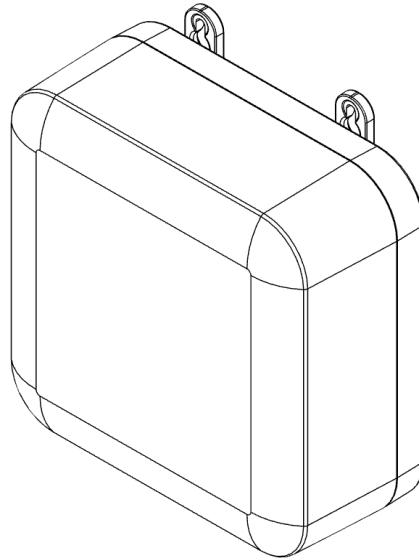

c. Wiring instructions



Electrical Hazards

Install as Fixed Wiring: The Wireless Gateway GW900-3G/4G must be installed with fixed wiring and an appropriate disconnect device. Do not use power cords or flexible cables. Have a qualified electrician perform all wiring. The disconnect device must meet the following criteria:

- **Type:** Use a switch or circuit breaker with a contact separation of at least 3 mm that meets the relevant requirements of IEC 60947-1, IEC 60947-2 and IEC 60947-3 and is suitable for the application.
- **Location:** It must be suitably located and easily accessible for operation.
- **Identification:** The disconnect device should be clearly marked as the disconnecting device for your device.
- **Single-Phase Equipment Specifics:**
 - **Disconnecting Both Poles:** For single-phase equipment, the disconnect device should ideally disconnect both the live (phase) and neutral conductors simultaneously. This ensures complete safety when disconnecting the equipment and is highly recommended.
 - **Single-Pole Disconnect Device:** If only a single-pole disconnect device is used, ensure that the neutral conductor in your mains supply is reliably identified. If the neutral is not clearly identified or not reliable, an additional two-pole disconnect device must be installed in the building's electrical system to ensure both phase and neutral conductors can be disconnected.

General Wiring Instructions:

- Cable:** Use only cables with an outside diameter of 6 to 13 mm. The recommended cable is HELUPOWER® H07RN-F LSOH 2 x 1.5 (part number 30757). An alternative option is Top Cable RZ1-K2X1,5-CCA B 1000. For electromagnetic compatibility (EMC) and immunity, 30 m is the maximum cable length for DC power supply. The cable recommended for installation must extend from the main protection (cable gland) over a length at least equivalent to half the diameter of the cord or cable: max. $\varnothing 13 \text{ mm} / 2 = 6,5 \text{ mm}$.

For the **ATEX versions** Wireless Gateway GW900-3G/4G-**EU Ex**, one of the cables mentioned above is attached with a cable length of 3 m. The following table provides the **wiring color codes** for power cables used with AC and DC power options for the specified models:

Model number	WG150160H-02 WG150164H-02	WG150160L-02 WG150164L-02
Wire Color	AC only	DC only
Brown	Phase (P)	+24 VDC (+)
Blue	Neutral (N)	0 VDC (-)

For the **HazLoc versions** Wireless Gateway GW900-3G/4G-**US Ex** a STOOW cable for NEC Extra-hard usage and 3 conductors is applied. The following table provides the **wiring color codes** for power cables used with AC and DC power options for the specified models:

Model number	WG150161H-02	WG150161L-02
Wire Color	AC only	DC only
Black	Live, Phase (L)	+24 VDC (+)
White	Neutral (N)	0 VDC (-)
Green/Yellow	Protective Earth (PE)	Protective Earth (PE)



Electrical Hazards

- **Stranded wire:** The end of a stranded conductor must not be consolidated by soft soldering at points where the conductor is under contact pressure.
- **Voltage Compatibility:** Only connect either AC input or DC input with the specified voltage for the device. Do not connect both types of input simultaneously.
- **Regulatory Compliance:** Ensure the Wireless Gateway GW900-4G is installed in accordance with all applicable national or local regulations relevant to the installation location.

As soon as the power supply (hardwired, 100-240 VAC or 24 VDC) works, there is nothing more to do as the device will command the data collections and will deal with the transmitters of the Wi-care system. The device cannot be accessed directly from the Internet by the user. Instead, it securely connects to the I-see server through a private encrypted communication tunnel.

CAUTION

Electrical Hazards – Non-Ex devices only

The Wireless Gateway GW900-3G/4G uses a cable gland M20x1.5 to ensure IP rating when connecting the fixed wiring. The cable gland fits cables with an external diameter of 6 to 13 mm.

Use fixed wiring⁴ with 2x 1,5 to 2,5 mm² conductors (PE is not connected, the power supply is double isolated). The following standards are relevant for different cable types:

- if rubber sheathed, be of synthetic rubber and not lighter than ordinary tough rubbersheathed flexible cord according to IEC 60245-1
- if PVC sheathed: not lighter than light PVC sheathed flexible cord according to IEC 60227-1
- halogen-free sheathed: compliance shall be in accordance with IEC 62821-1, IEC 62821-2 and IEC 62821-3.

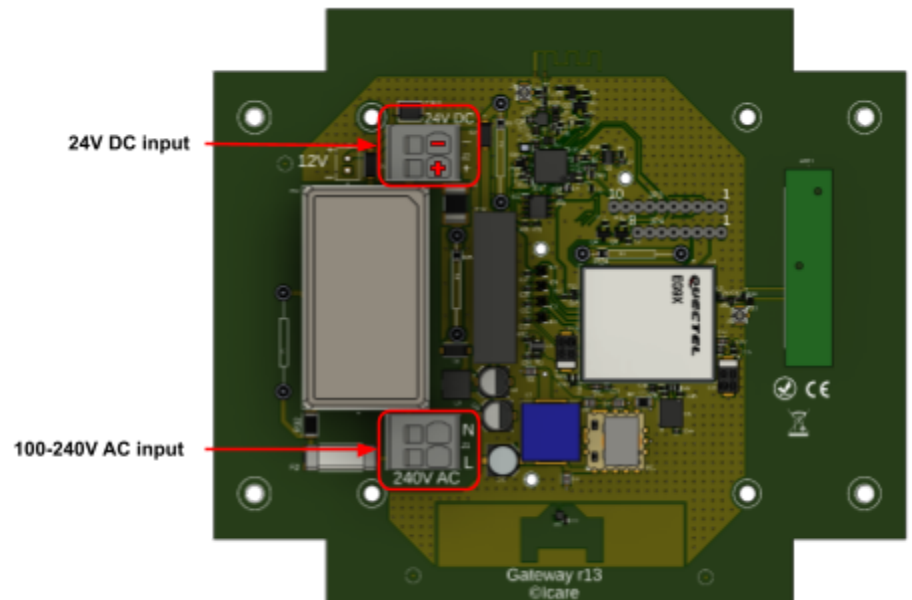

For a 24V power supply, do not use more than 30 meters of cable.

⁴ Recommended cables are HELUPOWER® H07RN-F LS0H 2 x 1.5 or Top Cable RZ1-K2X1,5-CCA B 1000.



Electrical shock hazard

The safety of the electronics of all Wireless Gateway GW900-3G/4G models is ensured by double insulation. However, for models with metal cable glands (all HazLoc models for USA/CAN), the cable gland is connected to a protective earth connector. Therefore, the following is relevant based on the model number:

Models WG150160-02, WG150160H-02, WG150160L-02, WG150161-02, WG150163-02, WG150164-02, WG150164H-02, WG150164L-02 of Wireless Gateway GW900-3G/4G are **Appliance Class II devices (double insulated)** designed not to have a safety connection to electrical earth. (Do not connect this device to earth.)



WG150161H-02 and WG150161L-02 are **Appliance Class I** devices intended for connection to an external conductor for protection against electric shock in case of a fault. Connect the cable with the PE connector to earth (ground). The earth termination is the last to take the strain. The earth wire must be longer than the other conductors to ensure proper strain relief.



Do not attempt to modify or alter the device in any way. Alterations may compromise the integrity of the double insulation and could result in electrical shock hazards. Inspect the device and its wiring for damage during routine maintenance. If you find damage, turn off the power using the circuit breaker and contact a qualified electrician.

i. Wiring steps (Non-Ex devices only)



Electrical Hazards

Prior to beginning any work, ensure that a qualified worker for electrical installations is assigned to the task. Verify that all necessary safety precautions are in place, including de-energizing the circuit and using appropriate lockout/tagout procedures.

Identify the circuit you will be working on and verify that it is de-energized using a voltage tester or other suitable testing device.

Unscrew the 4 screws of the enclosure and open the cover. Mount the cable gland provided in the box through the hole already made and screw the lock nut with a torque of 3,5 Nm (2.58 ft-lbf). Check if the cover seal is correctly in place and not damaged.⁵

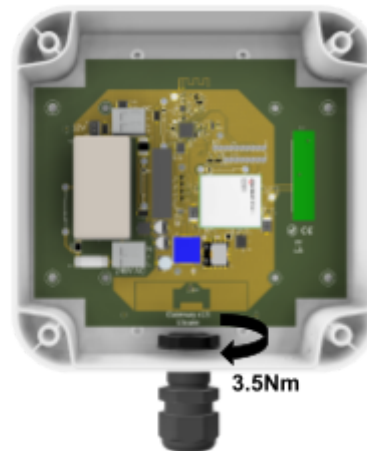

Pass the cable through the cable gland (outer wiring diameter from 6 to 13 mm). Strip the end of each wire by 10 mm (0.39 inches) and push the wires into the spring terminal in accordance with the voltage supply (24 V DC or 100-240 V AC, never use both). Check that each wire is securely connected. Finally, screw the thread-lock sealing nut and secure the cable with a torque of 2,5 Nm (1.84 ft-lbf). (→ Details on DC or AC installations in the pictures below)

⁵ The enclosure may only be opened by personnel trained by the manufacturer. Contact the [manufacturer or an authorized distributor](#) if you need this service.



Electrical Hazards

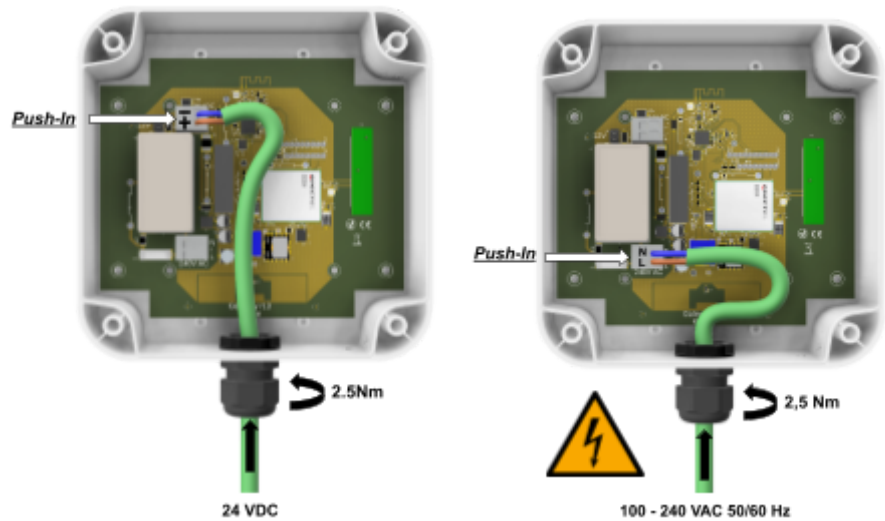

Close the box with the 4 screws (torque : 50 to 60 cN-m (71 to 85 ozf-in)) and mount it on the wall according to the mounting configuration (cf. Mounting Procedure).



D. Maintaining devices

To ensure the safe and reliable operation of the device, perform the following maintenance checks regularly, based on environmental conditions. Recommended intervals are provided below.

a. Explosive Atmospheres (all Ex devices)

 WARNING	<p>Ignition hazard (Ex devices only)</p> <ul style="list-style-type: none">● Electrostatic Discharge: The enclosure is made of a non-metallic material. To prevent the risk of electrostatic discharge, it must be cleaned only with a damp cloth. Do not use dry cloths, brushes, or any materials that could generate static electricity.
--	---

b. Class II (Combustible Dust) Locations (US Ex devices only)

 WARNING	<p>Risk of Explosion</p> <p>The explosion protection of this device is guaranteed only if the enclosure remains sealed. Do not open the enclosure for any reason. All service that requires opening the enclosure must be performed by the manufacturer or by personnel authorized by the manufacturer. Unauthorized opening of the enclosure voids the Ex certification and can lead to death or serious injury.</p>
--	---

To make sure the device operates safely and correctly, do the maintenance checks that follow. The **operator must define the frequency** of these checks based on the environmental conditions at the site.

i. Regular Inspection and Cleaning Schedule

Task	Minimum Frequency	Acceptance Criteria
Visual inspection for dust accumulation	Quarterly, or more often depending on site conditions	No continuous dust layer (>1 mm thick) is visible on the enclosure.
Clean the enclosure	When dust accumulation limit is reached	Enclosure surfaces are free from dust.
Check external integrity	Annually	The enclosure shows no cracks, damage, or deformation. The cable gland is secure and undamaged.
Check legibility of the marking label	At each cleaning	The certification label is clean and fully legible.

ii. Cleaning Procedure

Use only a damp cloth or an approved anti-static cloth to carefully remove all dust from the enclosure surfaces.



 WARNING	Do not use compressed air, dry brushes, or high-pressure washers to clean the device. These methods can create an explosive dust cloud or force dust past the enclosure seals.
--	--

iii. Inspection Checklist

During each maintenance task, visually inspect these items:

- **Dust Accumulation:** Examine the amount of dust build-up. If a layer more than 1 mm thick has formed, cleaning is necessary. Adjust the cleaning frequency to prevent such layers from forming.
- **Enclosure Integrity:** Look for external cracks, damage, or deformation on the enclosure. Make sure the cable gland is secure and not damaged.
- **Marking Legibility:** Make sure the certification label and all warning labels are clean and fully legible.

c. All devices

 WARNING	Electrical shock hazard		WG150161H-02 and WG150161L-02 are Appliance Class I devices intended for connection to an external conductor for protection against electric shock in case of a fault.	
<p>Models WG150160-02, WG150160H-02, WG150160L-02, WG150161-02, WG150163-02, WG150164-02, WG150164H-02, WG150164L-02 of Wireless Gateway GW900-3G/4G are Appliance Class II devices (double insulated) designed not to have a safety connection to electrical earth. (Do not connect this device to earth.)</p>				
<ul style="list-style-type: none">● Inspect Wiring: Check the wiring for wear every 12 to 48 months, or more frequently if the device is used in harsh environments. If you find any damage, turn off the power using the disconnect device and contact a qualified electrician for repairs.● Check Insulation: Examine the insulation covering the device every 12 to 48 months. Look for any signs of damage, such as cracks or tears. If you notice any damage, do not use the equipment, turn off the power using the disconnect device and contact the manufacturer or an authorized distributor immediately.				



Electrical hazards

- **General Condition of the Device:** Inspect the device for visible damage or problems every 12 to 48 months, or more frequently if the device is used in harsh environments. If you find any issues, turn off the power using the disconnect device. Contact the [manufacturer or an authorized distributor](#) for assistance.
- **Legible Marking Label:** Ensure the label on the device is legible. Check it during each maintenance visit. If the label is dirty, clean it gently with a damp cloth only.

E. Repairs

In general, please contact the [manufacturer or an authorized distributor](#) for support.

- **Ex devices:** Any repairs to the Ex devices must only be performed by the manufacturer or by authorized personnel, in accordance with the manufacturer's instructions, to maintain the device's certification and safety.
- **Wiring:** If you find any damage, turn off the power using the disconnect device and contact a qualified electrician for repairs.
- **Damaged devices:** Turn off the power with the disconnect device and contact the manufacturer or authorized distributor immediately. (→ [Manufacturer and Authorized Distributors](#))
- **Opening enclosure:** The enclosure may only be opened by personnel trained by the manufacturer. Contact the [manufacturer or an authorized distributor](#) if you need this service.

F. Taking Out of Service and Dismantling

In general, please contact the [manufacturer or an authorized distributor](#) for assistance with decommissioning and dismantling to ensure safety and compliance with relevant standards.

The steps to perform are:

1. **Qualified personnel:** Use a qualified electrician for all tasks.
2. **Power disconnection:** Ensure that all power sources are completely disconnected before beginning the process.
3. **Unmount enclosure:** Carefully detach the enclosure from its mounting point by removing the 4 screws from the brackets.
4. **Disposal:** We strongly encourage customers to follow our take-back policy for disposal of industrial electrical products at the end of their life cycle.

Please return these products either directly to our manufacturing facility or through our network of authorized distributors (→ [Manufacturer and Authorized Distributors](#)).

G. Specifications and environmental constraints

Specifications		EU/US Non-Ex	EU/US Ex AC only	EU/US Ex DC only
		WG150160-02	WG150160H-02	WG150160L-02
	WG150161-02	WG150161H-02	WG150161L-02	
	WG150163-02	WG150164H-02	WG150164L-02	
	WG150164-02			
Weight		558 g	1,7 kg incl. cable / 2,0 kg incl. cable *1	
Dimensions (length x width x height) [mm]		160*160*70		
Casing		Polycarbonate; flameproof min. V-0		
Environmental Ratings		IP66 / 4X *2 *3 Indoor and outdoor use	IP64 / 4X *2 *3 Indoor and outdoor use	
Operating Temperature/ Humidity		-20 °C to +75 °C / 0-95% relative humidity, non-condensing	-15 °C to +59/60 °C *4 0-95% relative humidity, non-condensing	
Storage Temperature/ Humidity		-40 °C to +85 °C 0-95% relative humidity, non-condensing		
Mounting		Wall mounting in locations with low risk of mechanical danger, 4 Mounting brackets *5		
Power Supply voltage	AC input	100-240 VAC 50/60Hz		–
	DC input	24 VDC	–	24 VDC
Power consumption (max. rated)	AC input	1,8 W		–
	DC input	1,8 W	–	1,8 W
Max. current (fuse)	AC input	≤ 3,15 A	0,8 A	
	DC input	≤ 3,15 A	–	0,8 A

Specifications	EU/US Non-Ex	EU/US Ex AC only	EU/US Ex DC only
		WG150160-02 WG150161-02 WG150163-02 WG150164-02	WG150160H-02 WG150161H-02 WG150164H-02
Appliance classes IEC 61140	Class II	Class I or II * ⁶	
Wireless protocol	Secure Open Thread (IEEE 802.15.4) / LTE cat1		
Broadcast Range	100 m (line of sight)	> 30 m (line of sight)	
Physical interfaces	Push-in Terminal block for fixed power installation	–	
Terminal Blocks	Push-in spring connection * ⁷	–	
Ventilation	Closed enclosure, clearance of 10 cm for external airflow required		
Altitude Limitation	up to 2.000 meters (6,561 feet) above sea level		
Overvoltage category	Category II		
Pollution Degree Rating	Pollution degree 3		
Prospective current	1.500 A for AC input 100 A for DC input	1.500 A	100 A
Fixed wiring cable	→ see table "Power Cable" on the following page		
Means of Disconnect	Not provided: External circuit breaker		

Specifications		EU/US Non-Ex	EU/US Ex AC only	EU/US Ex DC only
		WG150160-02	WG150160H-02	WG150160L-02
	WG150161-02	WG150161H-02	WG150161L-02	
	WG150163-02	WG150164H-02	WG150164L-02	
	WG150164-02			
Fixed wiring cable	Cable options	Not provided	HELUPOWER® H07RN-F LSOH 2 x 1.5 / Top Cable RZ1-K2X1,5-CCA B 1000	LAPP ÖLFLEX POWER MULTI 3 G 1.5
	Length	max. 30 m for DC	3 m	
	Nominal cross section	1,5 to 2,5 mm ² *7	1,5 mm ²	
	Nominal overall diameter	6 to 13 mm	8,5 to 9,9 mm / 9,3 mm	10.1 mm
	Minimum Bending Radius	Refer to your cable documentation	40,0 mm / 46,5 mm	40,4 mm
	Insulation	Refer to your cable documentation	Special rubber	Specially formulated PVC
	Color Coded Wiring	-	→ Wiring instructions	

Notes:

- *1 EU Ex and GL Ex models (WG150160H-02, WG150160L-02, WG150164H-02, WG150164L-02) with approx. 1,7 kg,
US Ex versions (WG150161H-02, WG150161L-02) with approx. 2,0 kg.

*2

	<p>The enclosure may only be opened by personnel trained by the manufacturer. Contact the manufacturer or an authorized distributor if you need this service.</p>
---	---

- *3 All variants are designed for industrial applications in both indoor and outdoor environments, with an IP66 or IP64 rating. To comply with North American requirements, only the US variants are rated for Type 4X.
- *4 EU Ex and GL Ex variants (WG150160H-02, WG150160L-02, WG150164H-02, WG150164L-02) with max. rated ambient temperature of 60 °C, US Ex variants (WG150161H-02, WG150161L-02) are rated for a maximum ambient temperature of **≥59 °C**. Specific variants are rated for a maximum ambient temperature of 60 °C. Please refer to the marking label for exact specifications.
- *5 Dimensions of mounting brackets:

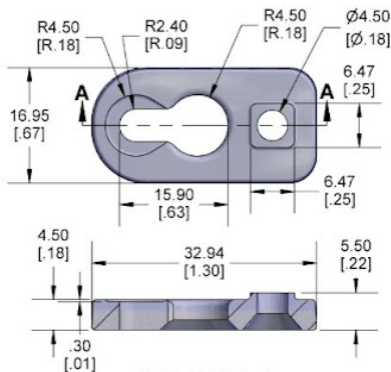

- *6 EU Ex and GL Ex variants (WG150160H-02, WG150160L-02, WG150164H-02, WG150164L-02) are Class II, US Ex variants (WG150161H-02, WG150161L-02) are Class I
- *7 Intended for application of 2x 1,5 to 2,5 mm²:

Power cable specification	min	max
Conductor cross section solid	0,2 mm ²	4 mm ²
Conductor cross section flexible	0,2 mm ²	2,5 mm ²
Conductor cross section flexible, with ferrule without plastic sleeve	0,25 mm ² Stripping length 8 mm	2,5 mm ² Stripping length 8 mm
Conductor cross section flexible, with ferrule with plastic sleeve	0,25 mm ² Stripping length 8 mm	1,5 mm ² Stripping length 8 mm
Conductor cross section American wire gauge (AWG)	24	12

H. Compliance

a. Ex Certifications

Scheme	Ex marking	Certificate number	Affected models
IECEX	Ex eb mb IIC T4 Gb (Gas atmospheres)	IECEX CSA 25.0040X	WG150160H-02, WG150160L-02, WG150161H-02, WG150161L-02
		Pending	WG150164H-02, WG150164L-02
ATEX	Ⓔ II 2 G Ex eb mb IIC T4 Gb (Gas atmospheres)	CSANe 25ATEX1082X	WG150160H-02, WG150160L-02
		Pending	WG150164H-02, WG150164L-02
CSA HazLoc	Gas atmospheres: Class I, Div 2, Group ABCD Class I Zone 1 AEx eb mb IIC T4 Gb Combustible Dust atmospheres: Class II, Div 2, Group EFG T135°C	CSA 25CA80218472X	WG150161H-02, WG150161L-02

i. Assessment standards of the Ex certifications

IECEX	ATEX	CSA HazLoc
IEC 60079-0:2017 Ed. 7	EN IEC 60079-0:2018	CSA C22.2 No. 62368-1:19 + Update 1:2021
IEC 60079-7:2017 Ed. 5.1	EN IEC 60079-7:2015+A1:2018	CSA C22.2 No. 213:17, Updates 1 & 2 & 3 (R2022)
IEC 60079-018:2017 Ed. 4.1	EN 60079-18:2015+A1:2017	CSA C22.2 No. 60079-0:19 (R2024)
		CSA C22.2 No. 60079-7:16 (R2021)
		CSA C22.2 No. 60079-18:16+AMD1:2018 (R2021)
		UL 62368-1-2021

IECEx	ATEX	CSA HazLoc
		UL 121201-2021
		UL 60079-0-2024
		UL 60079-7-2021
		UL 60079-18-2023

b. Radio Compliance for WG150160y-02

The models for the Brazilian market with ANATEL approval comply with:

Resolução 680 – ATO 14448

Este equipamento não tem direito à proteção contra interferência prejudicial e não pode causar interferência em sistemas devidamente autorizados. Para maiores informações, consulte o site da ANATEL – www.gov.br/anatel.

c. Radio Compliance for WG150161y-02

IMPORTANT NOTE: This equipment complies with FCC radiation exposure limits set forth for an uncontrolled environment. This equipment should be installed and operated with minimum distance 20 cm between the radiator & your body.

i. Federal Communications Commission (FCC)

Changes or modifications not expressly approved by the party responsible for compliance could void the user’s authority to operate the equipment. (FCC Part 15.21)

Supplier's Declaration of Conformity – 47 CFR § 2.1077 Compliance Information

Unique Identifier: WG150161y-02 (with y = [blank], H or L)

Responsible Party – U.S. Contact Information

I-care Reliability Inc.
11200 Westheimer Rd., Ste 625 -
Houston, TX
77042
+1 281-940-5383, <https://www.icareweb.com>

FCC Compliance Statement

This device complies with Part 15 of the FCC Rules.

The radio transmitters in this device meet FCC certification requirements.

The other parts of this device are the non-radio digital device and peripheral parts. These parts meet the requirements specified in FCC Rule Part 15B.

Operation is subject to the following two conditions:

- (1) This device may not cause harmful interference, and
- (2) this device must accept any interference received, including interference that may cause undesired operation.

ii. Innovation, Science and Economic Development Canada (ISED) Compliance (RSS GEN Issue 5)

This device contains licence-exempt transmitter(s)/receiver(s) that comply with Innovation, Science and Economic Development Canada's licence-exempt RSS(s). Operation is subject to the following two conditions:

- (1) This device may not cause interference
- (2) This device must accept any interference, including interference that may cause undesired operation of the device.

d. Radio Compliance for WG150164y-02

当該機器には電波法に基づく、技術基準適合証明等を受けた特定無線設備を装着している。

(This equipment contains specified radio equipment that has been certified to the Technical Regulation Conformity Certification under the Radion Law.)

I. *Manufacturer and Authorized Distributors*

Please contact one of the following companies for authorized support and technical assistance on the device.

a. Manufacturer

I-care SRL

Rue René Descartes 18
7000 Mons
Belgium

b. Legal Representatives

i. USA

I-care Reliability Inc.

11200 Westheimer rd.
Suite 625 - Westheimer Central Plaza
TX 77042 Houston
USA

ii. Brazil

SGQEX CERTIFICACAO E CONSULTORIA LTDA

Rua Maria Luísa, 26
Sala 8
Piraporinha, Diadema
SP 09951-330
Brazil
CNPJ: 41.890.176/0001-43

c. Authorized support via email

Feel free to contact the official email support in local languages from the manufacturer or legal subsidiaries:

Belgium - Dutch	customer.support.benl@icareweb.com
Belgium - French	customer.support.befr@icareweb.com
France	customer.support.fr@icareweb.com
Germany	customer.support.de@icareweb.com
Poland	customer.support.pl@icareweb.com
Switzerland	customer.support.ch@icareweb.com
The Netherlands	customer.support.nl@icareweb.com
USA / North America	support.us@icareweb.com

d. Authorized Distributors

Here is a non-exhaustive list of authorized distributors (this list is subject to change):

- I-care Asia Co Ltd, 519-C, Baekbeom-ro 513, Yongsan-gu, Seoul, South Korea
- I-Care Australasia Pty Ltd, U1/35 Beach Road, SA 5165, Christies Beach, Australia
- I-Care Deutschland GmbH, Dennewartstr. 25-27, 52068 Aachen, Germany
- I-care Polska SP Z.O.O., Ul. Puzkarska 9, 30-644, Kraków, Poland
- I-care Reliability Brazil LTDA, Avenida Doutor Chucri Zaidan - 1550 - Conj 1510 - Vila São Francisco, 04711-130, São Paulo, Brazil
- I-care Reliability España sl, Edificio ESPAITEC 2 - Universitat Jaume I Avda Sos Baynat, Castellón de la Plana, Spain
- I-care Reliability Inc., 11200 Westheimer rd., Suite 625 - Westheimer Central Plaza, TX 77042, Houston, USA
- I-care Reliability UK Limited, Faulkner House, Victoria Street, AL1 3SE, St Albans, United Kingdom
- I-care SAS, 89, Rue George Stephenson B7, 59300, Famars, France
- I-care Suisse SA, Le Chateau 3, 2028 Vaumarcus, Switzerland
- Services Fiabilité I-care Inc, 1000 Boul. Crémazie Est - Bureau 805, Québec H2P 2X2, Montréal, Canada

J. Additional information

a. Warranty

Please contact the [manufacturer or an authorized distributor](#) for warranty assistance.

For detailed information, please refer to the document called “General sales terms and conditions Wi-Care” in attachment.

b. Frequent problems and solutions provided

If certain devices are not recognised by the software I-see:

1. Check if the device has all been enabled. Please remove and dispose of any remaining plastic tab on the device to activate the battery.
2. The device needs a Gateway to cooperate with. Is a compatible Gateway within range of the device? Change positions of the device or the Gateway. Please refer to the user manual of the Gateway.
3. Does the device still have battery power? The device is designed to last for approximately 5 years.
4. Have you properly configured and enabled the different tasks? Have you left time for the Gateway to synchronize tasks? You should leave +/- 1 hour between the time when the task is created and the time when the measurement must be taken. For more details, please refer to the documentation of the software I-see.
5. Has the device been subjected to shock or treatment that could damage it? If so, please contact the manufacturer.

For more information, please refer to the user manual of the Gateway and the documentation of the software I-see.

c. Practical information

I-Care: <http://www.icareweb.com/>

I-See: <https://isee.icareweb.com/login/>

Wi-Care support: customer.support@icareweb.com

Phone number: +32 65.45.72.14

YouTube channel: https://www.youtube.com/channel/UCQ-ne_g6kz9M53TB9KZfbww

Before you contact us (→ [Authorized support via email](#)), please make sure you have the following information ready so that Support can process your request as efficiently as possible:

- **product name and serial number,**
- **a complete description of the problem,**
- **the exact wording of any error messages.**

End of document